



**I**      **DE**      **Einbauanleitung**  
**Dezentrales Lüftungssystem mit**  
**Wärmerückgewinnung Typ Ne<sup>xx</sup>t**  
**Einschub**

- Bitte an den Nutzer weiterleiten -

**II**      **EN**      **Installation Manual**  
**Decentralised Ventilation System**  
**with Heat Recovery Type Ne<sup>xx</sup>t**  
**Slide-in unit**

- Please pass on to user -

Content	Page:
Reference these directions, safety instruction, waste disposal	16
Technical data, mounting position, assembly features, area of application	17
Dispatch units	18
Installation - Finished installation	19
Electrical connection - wiring diagrams	21
Operating element, DIP-switch setting	23
Affixing of modules on the control	24
Filter replacement	25
Close-off of the inside screen, USB connection	26
Note on LUNOS exterior coverings, cleaning, addition / replacement parts	27

### Reference these directions

- These directions describe the surface mounting and concealed installation of the decentralized ventilation devices with heat recovery Type Ne<sup>xt</sup>
- Before the installation, read these directions through carefully and completely! It is absolutely necessary to consider the general notes on safety and the safety symbols with notes in the text.
- These directions are to be handed over to the user on completion of the installation (tenant, owner, building administration etc.).



This symbol warns you of the danger of injury.



This symbol warns you of the danger of injury through electric current.

### Notes on safety



**Caution!** All assembly work on the ventilation device may be implemented only with all-pole disconnected mains voltage! The ventilation device is double-insulated according to Protection Class II and the protective ground terminal is dispensed with!



**Attention!** The electrical connection may be carried out by authorized skilled personnel only and according to valid VDE 0100!



**Attention!** This device (filter change/cleaning) may not be operated by children and persons who are not capable of safely operating it due to their physical, sensory or intellectual capabilities or their inexperience or lack of knowledge. Children should be supervised in order to ensure that they do not play with the device.

### Waste disposal



Dispose of the packaging sorted according to material. If you wish to detach anything from the device, dispose of it according to current stipulations. The communal agency can provide information.

Device voltage:	230 V AC 50 Hz
Control voltage:	1 - 10 V DC SELV
Electrical power consumption:	5,7-40/46,5 W
Protection type:	IP 22
Volume flow:	15-90/115 m <sup>3</sup> /h

**Installation position**

Mount the ventilation device with a recommended lateral minimum separation distance of 30 cm and a recommended minimum separation distance of 15 cm above and below.

The side separation distance serves to ensure the ventilation function, the separation distance above and below the assembly freedom.

We recommend to install the device at an altitude of 1,50 meters to ensure a user-friendly operating.

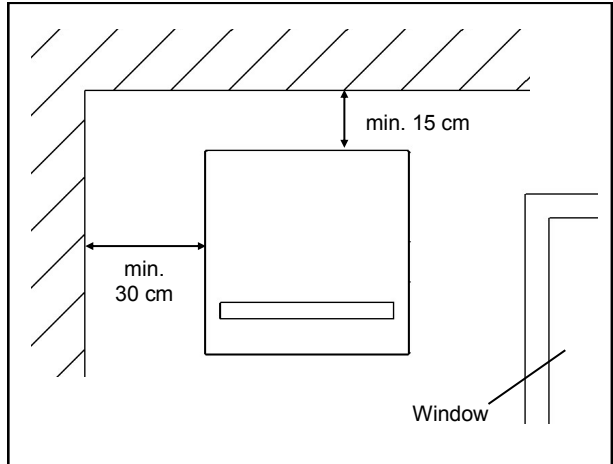

**Installation features**

- The ventilation device must be installed indoors vertically on an external wall.
- Only one installation position is possible and this should indicate air ports to the right and left above.
- The ventilation device must always be freely accessible for operation and maintenance, the air ports may not be built over, adjusted or covered
- In case of retrofit installation, make sure that there are no supply lines lie (e.g. gas, water, current) in the area of the wall break-through
- Make sure that the wall break-through corresponds to the local requirements, as appropriate pull in a lintle

**Area of application**

Temperature application range: - 15°C to 40°C +

Can be used with a relative air humidity level up to 65% in the indoor area (not condensing). In case of exceeding the employment limits, switch off the device and close off inside screen. Ensure a fresh air supply through window ventilation.

If condensate is generated, it is automatically discharged to the outside. Please make sure in the winter that there is no ice formation on the outer grid and in the area around it.

Check the delivery for completeness and trouble-free status!

**Slide-in unit with counter-flow heat exchanger    Slide-in unit with cross-flow heat exchanger**

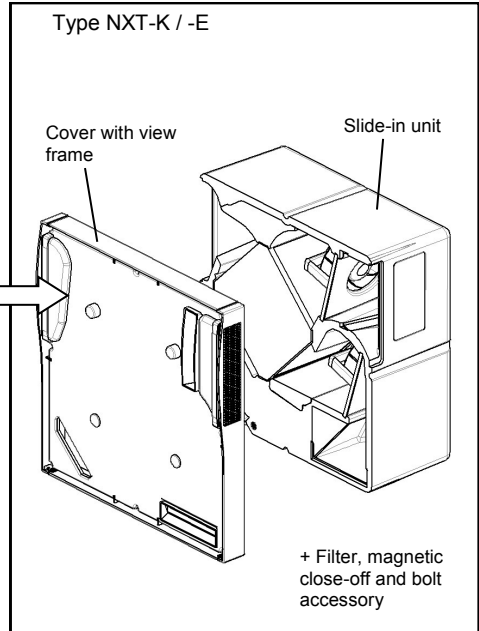
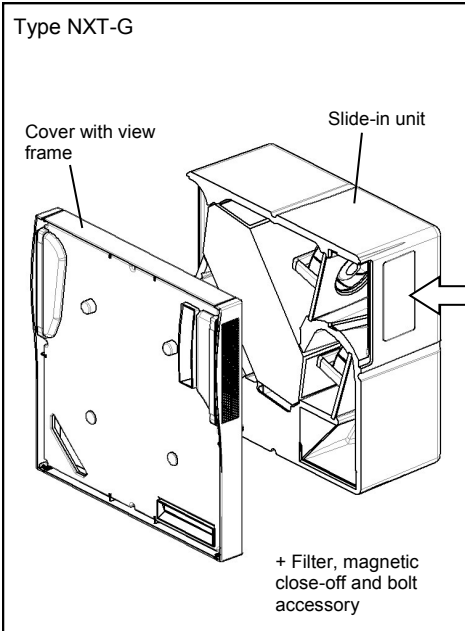

**Inside screen**

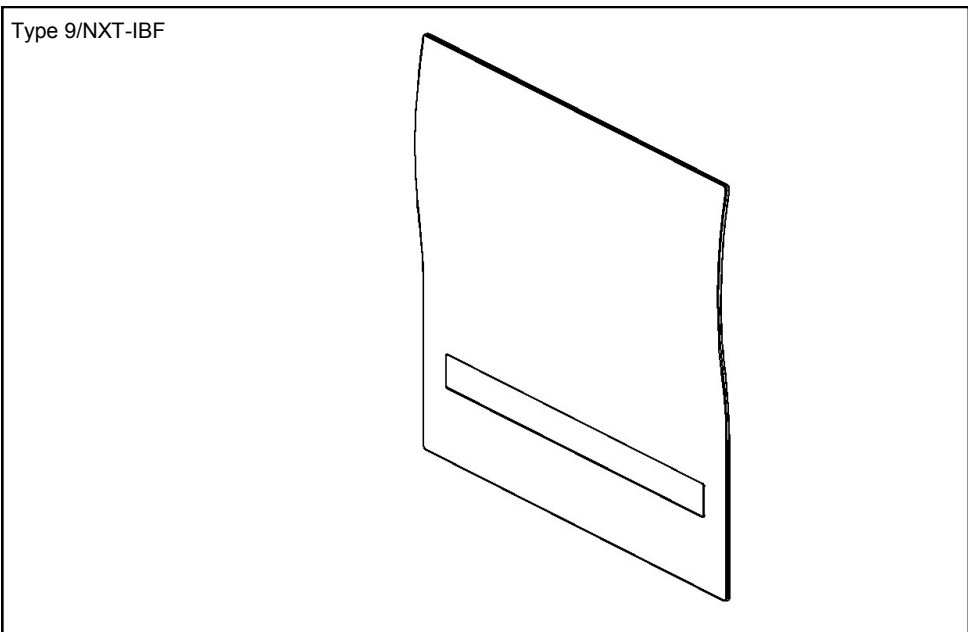

Insert the slide-in unit into the wall installation housing!

Note: The slide-in unit must joint exactly into the electrical flap close-off and on the mains connection circuit board!  
With the insertion the electrical connection of the slide-in unit is realized!

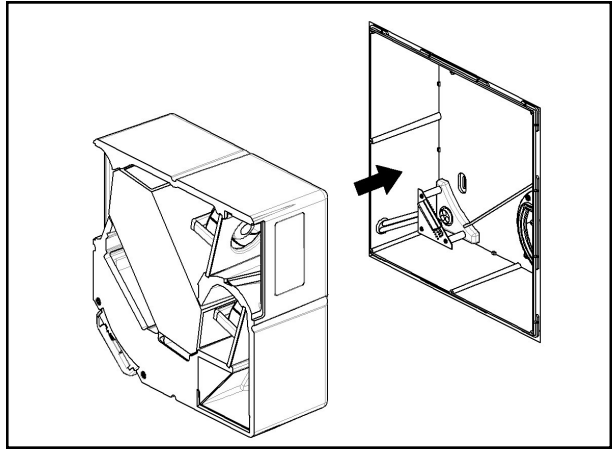

Place the housing lid onto the wall installation housing with the slide-in unit contained in it! Screw the housing lid onto the wall installation housing with the enclosed bolts!

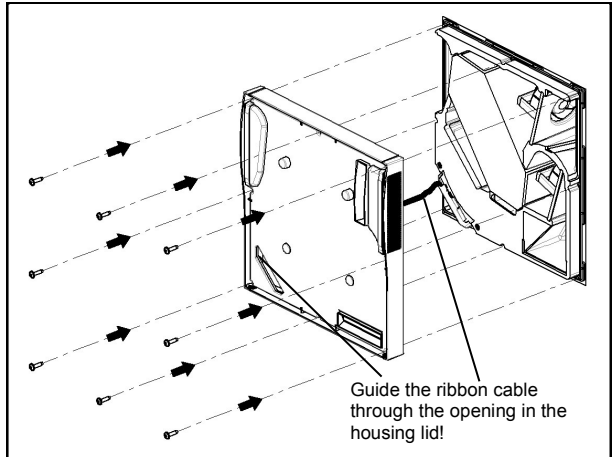

Insert the filters!

Note the correct flow-streaming direction of the filters, where this is marked with an arrow!

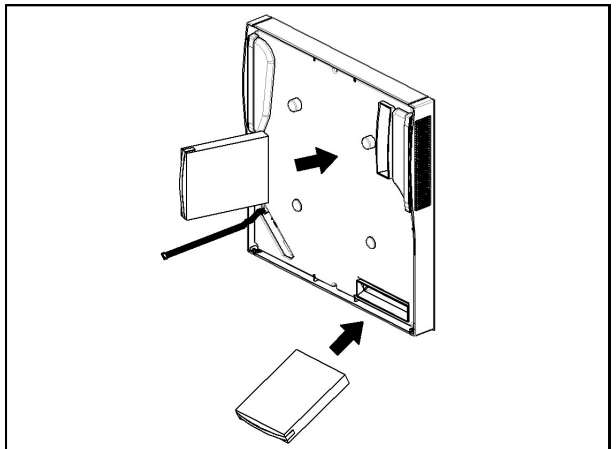

Connect the operating element of the inside screen to the control unit of the slide-in unit!

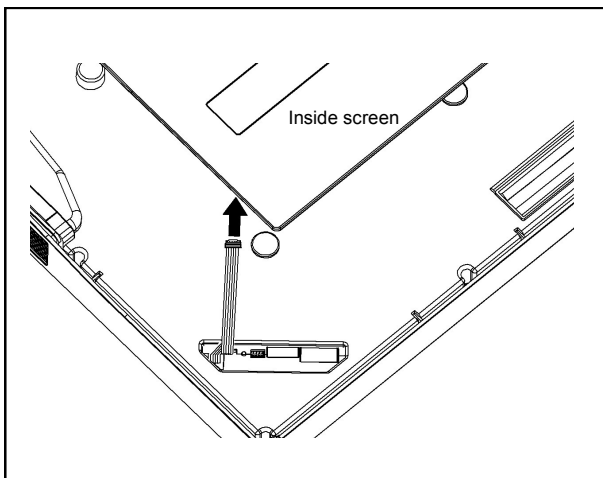

Place on the inside screen; it is held by magnets contained in the four fastening points!

Finished!

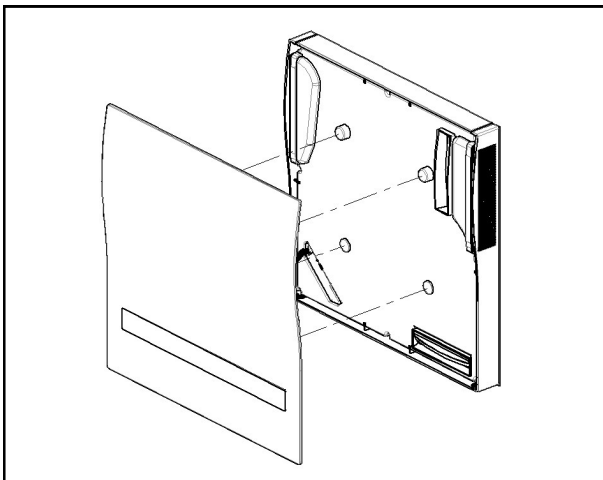

Notes on safety



Caution! All assembly work on the ventilation device may be implemented only with all-pole disconnected mains voltage!

Set all connecting lines voltage-free before connection of the ventilation device to the mains voltage! (Disconnection from the mains with at least 3 mm contact gap, e.g. all-pole disconnection elec. protection).



Every electric circuit associated with this ventilation system must be equipped with a leakage current protection (e.g. residual-current-operated circuit breaker)!

Electrical connection by a specialist only!

Use maximum NYM - J 5 x 1.5 mm<sup>2</sup> as a mains cable. The connection of the PE conductor is absolutely necessary!

For the connection of the TAC and/or the gesture control, use cables of the type J-Y(St)Y (2x2x0.8), max. 1.5 mm<sup>2</sup>! The pigtail connections for the electrical flap close-off are enclosed ex-works!

Mains connection circuit board and mains power connection terminals for the support are labeled! Do not loosen one of the cables already connected by the manufacturer to the mains connection circuit board under any circumstance!

Wiring diagrams

Operation over the operating element on the device and representation of the connections of the electrical flap close-off, the gesture control and the TAC

Mains connection circuit board (view from below)

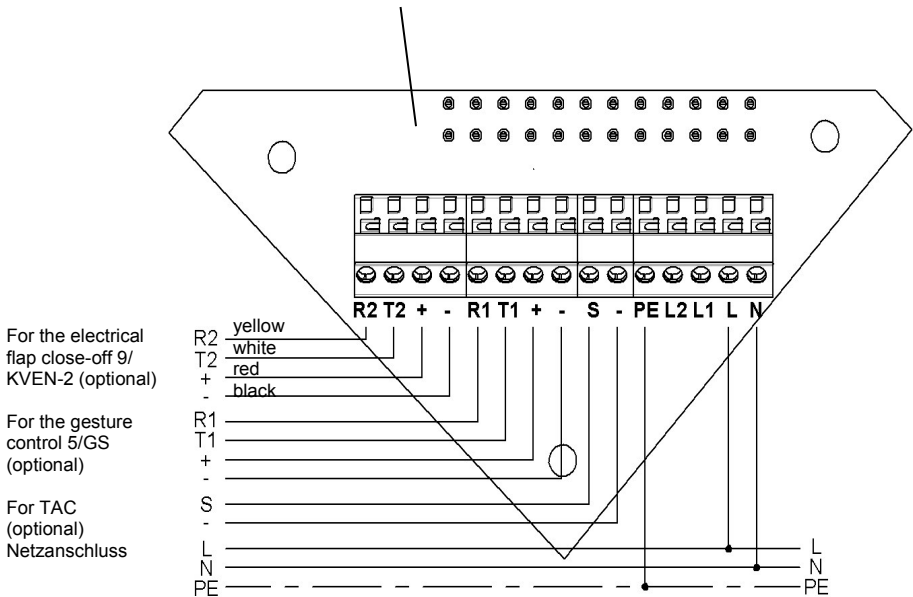

Manual switching of the volume flow stages over an external two-pole button:  
 L1 = Volume flow stage more; L2 = Volume flow stage less  
 Note: DIP switch 2 must be in position OFF for that.

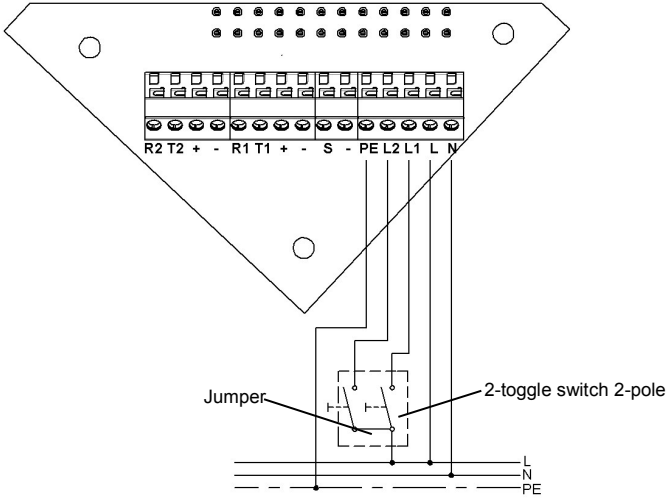

Manual switching of the volume flow stages over an external single-pole button on L1 and simultaneous operation of one or more air-extraction fans over coupling on L2 for the compensation of the additional vacuum pressure arising from the exhaust-air ventilators.  
 L1: 1x key: Volume flow stage more; 2x key: Volume flow stage less  
 Note: DIP switch 2 must be in position ON for that.

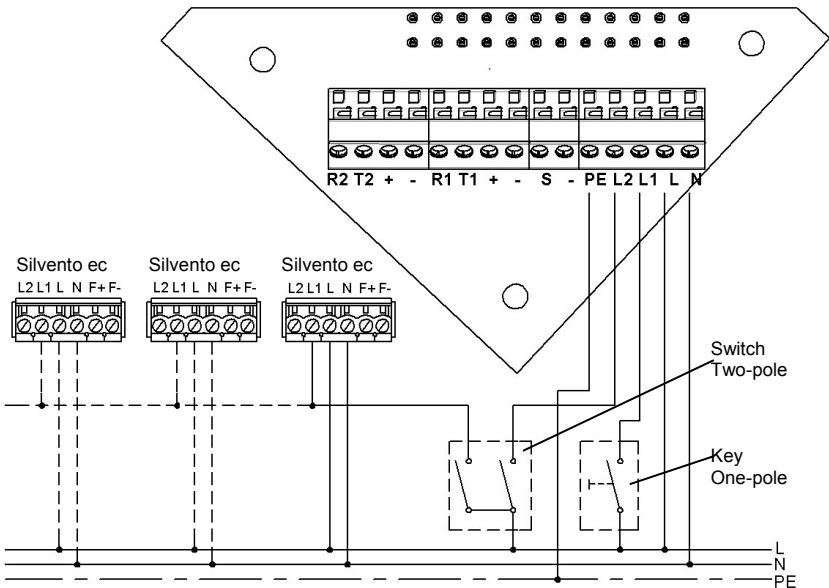



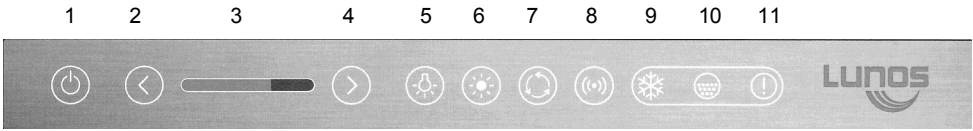

1	ON/OFF	Key and indication
2	Volume flow less	Key
3	Volume flow stage	Indication
4	Volume flow more	Key
5	Possibility of the disconnection of the key back-lighting	Key and indication
6	Summer circuit	Key and indication
7	Automatic operation	Key and indication
8	WLAN	Key and indication
9	Antifreeze operation warning display	Indication
10	Filter change indication	Indication
11	Error indication	Indication

A detailed description of the functions of the operating element can be found on [www.lunos.de!](http://www.lunos.de!)

**DIP-switch setting**

**Ex-works setting:**  
White DIP switch

Ne<sup>xt</sup> NXT-G

1 2 3 4

ON

Ne<sup>xt</sup> NXT-K / -E

1 2 3 4

ON

■	□	□	□	Ne <sup>xt</sup> NXT-G
■	□	□	□	Ne <sup>xt</sup> NXT-K
□	■	□	□	Standard key function according to wiring diagram 2
□	■	□	□	Special function according to wiring diagram 3
□	□	■	□	Only exhaust air with activated summer circuit
□	□	■	□	Only supply air with activated summer circuit
□	□	□	■	Key lock. Operating element can not be operated (function available from FW 0.98)
□	□	□	■	

1 2 3 4

**Attention! Do not change the adjustment of the DIP switch 1!**



Caution! All assembly work on the ventilation device may be implemented only with all-pole disconnected mains voltage!

Set all connecting lines voltage-free before connection of the ventilation device to the mains voltage! (Disconnection from the mains with at least 3 mm contact gap, e.g. all-pole disconnection elec. protection).

The control of the Ne<sup>xt</sup> can be extended by pinning of modules. For the radio module, the larger bag is planned to the right.

Remove the inside screen and loosen the plug connection to the operating element. Plug the module into the bag provided for that as represented.

Ensure that the module is placed on correctly and completely!

Pin the operating element again and place on the inside screen again.

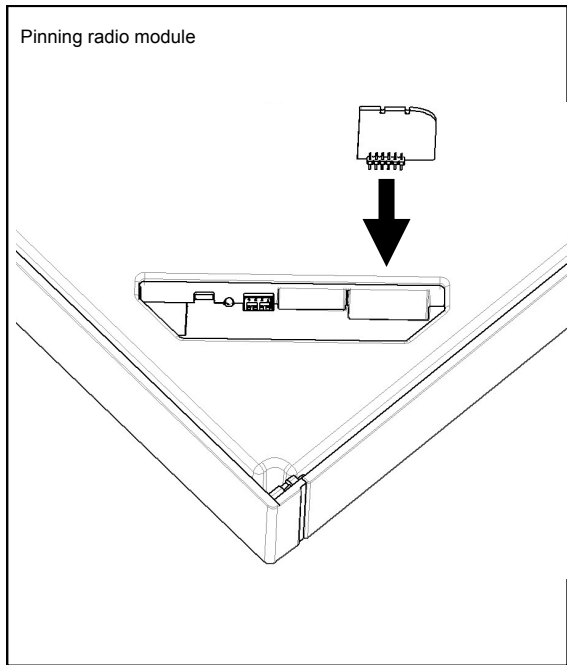



Caution! All assembly work on the ventilation device may be implemented only with all-pole disconnected mains voltage!

Set all connecting lines voltage-free before connection of the ventilation device to the mains voltage!

(Disconnection from the mains with at least 3 mm contact gap, e.g. all-pole disconnection elec. protection).

A soiled filter is signaled through the filter change indication.  
 Remove the inside screen for the filter change and loosen the plug connection to the operating element.  
 Withdraw the two filters from their receptacles. Insert two new filters. Pay attention in this case to the direction of flow marked on the filters.  
 Reset the filter change indication over the corresponding key - the lamp of the LED below the key goes out.  
 Place the operating element on again and place on the inside screen again.

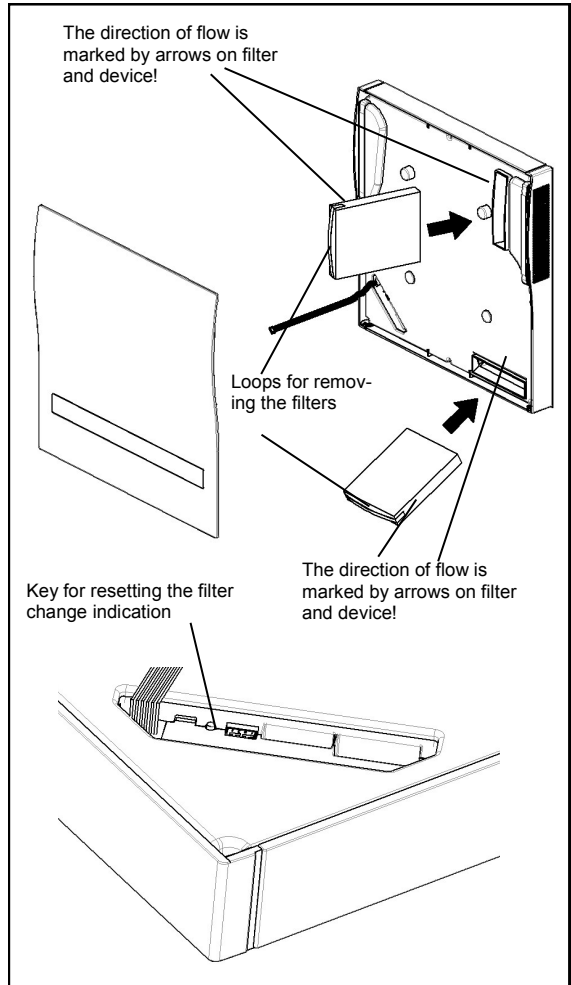

Please note here the filter changes implemented by yourself:

Filter change date	Probable filter change	Inserted filter type

In case of electrical flap close-off not being present, the inside screen can be closed off with the magnetic fasteners if necessary: Switch off ventilation device and, with the red side facing out, place fasteners from externally in front of the ventilation grating.

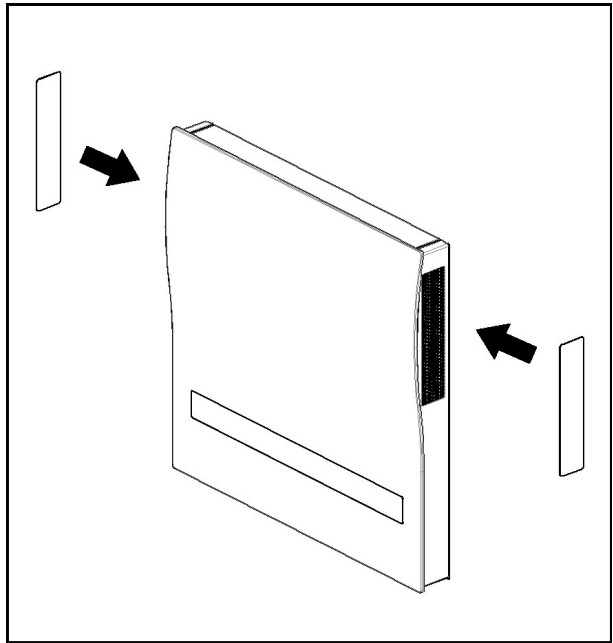

USB connection

The USB connection can be used for communication with a PC and the possibility of program updates exists for your Ne<sup>xt</sup>. Connect Ne<sup>xt</sup> and PC with a USB cable. For updating the firmware, download the update file ([www.lunos.de](http://www.lunos.de)). The directions for the implementation of the update are enclosed with every update file.

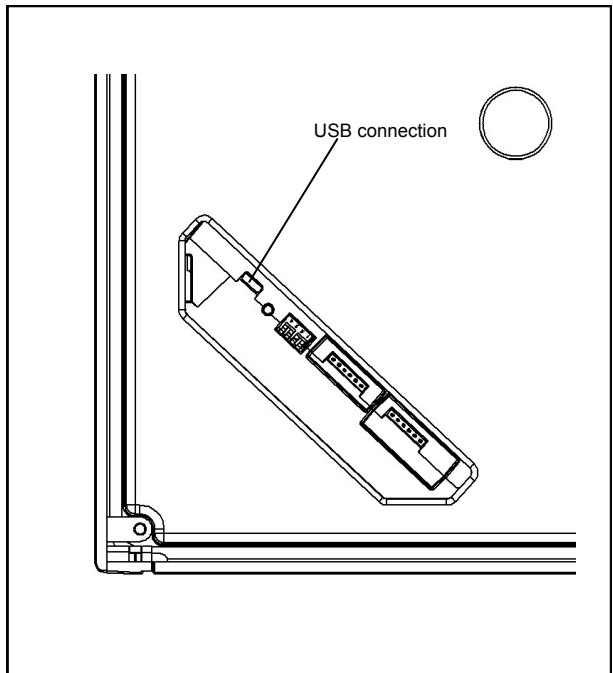

The external coverings of fully-synthetic material offered by LUNOS provide for a high resistance to driving rain and can be employed in Stress Group III in accordance with DIN 4108-3 (2014-11). Metallic or metallic-coated external grids in Stress Group I in accordance with DIN 4108-3 (2014-11) can be employed.

In the case of buildings in locations exposed to wind or the hazard of strong winds and rain on the external coverings, further weather-protection measures are to be taken as appropriate.

**Cleaning**

If required, wipe inner facade and housing parts with a dry soft cloth.

Filter change and cleaning may not be implemented by children and persons who are not capable of safely to implement these actions due to their physical, sensory or intellectual capabilities or their inexperience or lack of knowledge.

**Additional / Replacement parts**

Filter M5 (2 Items)	9/FNXT-5	Order No.: 040 109
Filter F7 (2 Items)	9/FNXT-7	Order No.: 040 110
Filter F9 (2 Items)	9/FNXT-9	Order No.: 040 111
Radio module	FM-EO	Order No.: 040 083

**LUNOS Germany**

LUNOS Lüftungstechnik GmbH  
für Raumlufsysteme  
Wilhelmstr. 31  
13593 Berlin · Germany

Phone +49 30 362 001-0  
Fax +49 30 362 001-89  
info@lunos.de  
www.lunos.de