



- I** **DE** **Einbauanleitung
Außenwandluftdurchlässe
Typ ALD und ALD-S**
- Bitte an den Nutzer weiterleiten -
-
- II** **EN** **Installation Manual
Outer Wall Air Vents
Type ALD and ALD-S**
- Please pass on to user -

Contents**Page:**

About this manual, Disposal, Installation position, Note regarding LUNOS outer covers	12
Installation examples	13
Shipping units	14
Assembly: ALD	14
Assembly: ALD-S	15
Assembly in connection with LUNOtherm and LUNOtherm FS	16
Filter replacement, Additional parts and replacement parts	17

About this manual

- Read this manual carefully and completely before assembly! Always observe the general safety instructions and the safety symbols with information in the text.
- Hand out this manual to the user (tenants, proprietors, property management etc.) after completing assembly.

Disposal

The packaging must be sorted before disposal. If you wish to dispose of the device, observe the currently applicable regulations. The municipal office in charge will provide information.

Installation position

Do not position the device above sensitive furniture, surfaces or pictures; the wall beneath the device should remain unused.

Do not position the device above or near room thermostats.

Note regarding LUNOS outer covers

The solid plastic outer covers provided by LUNOS ensure high resistance to driving rain and can be used in Stress Group III pursuant to DIN 4108-3 (2012-04). Metal or metal-coated covers can be used in Stress Group I pursuant to DIN 4108-3 (2012-04).

In the case of buildings exposed to wind or the risk of strong winds and rain to the outer covers, further measures of weather protection may be required.

Note: In the installation examples the inner screen 9/IBE is shown as internal closure and a outer grille Ø180 mm as external closure. Here, other internal and external closures from the LUNOS product range are also possible.

ALD

- 1 - Inner screen 9/IBE with filter and, if required, airflow regulator
- 2 - Wind pressure relief 9/WDS
- 3 - Wall-tube 9/R 160
- 4 - Sound-absorber 9/SD-S
- 5 - External closure

Wall structure (simplified depiction):
 a - Internal plaster; b - Masonry c - Thermal insulation; d - External plaster

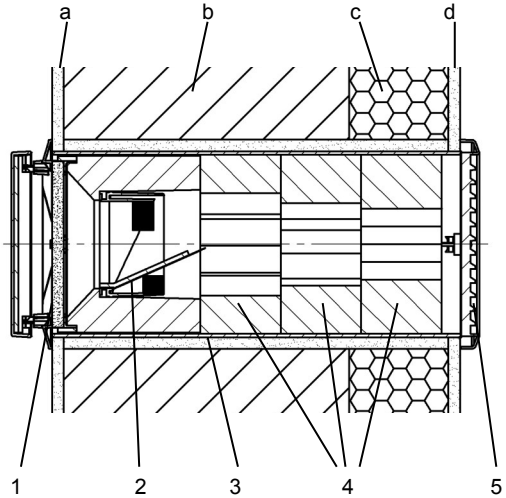

ALD-S

- 1 - Inner screen 9/IBE with filter
- 2 - Sound insulation ring
- 3 - Wall-tube 9/R 160
- 4 - Sound-absorber 9/SD-SK
- 5 - External closure

Wall structure (simplified depiction):
 a - Internal plaster; b - Masonry c - Thermal insulation; d - External plaster

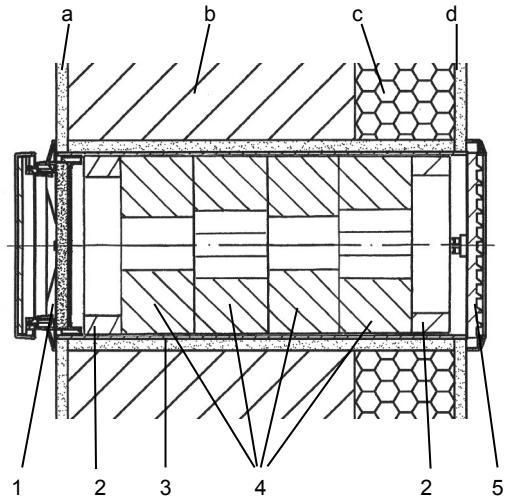

ALD in connection with the facade element LUNOthem

Assembly in **thin-layered plaster** systems

- 1 - Inner screen 9/IBE with filter
- 2 - Wind pressure relief 9/WDS
- 3 - Wall-tube 9/R 160
- 4 - Sound-absorber 9/SD-S
- 5 - Sound absorber endpiece
- a) - Plaster
- c) - Reinforcement and reinforcement adhesive (according to approved ETICS)
- d) - Lower end plate
- e) - Plaster frame
- f) - Insect protection screen
- g) - Insulation (according to approved ETICS))

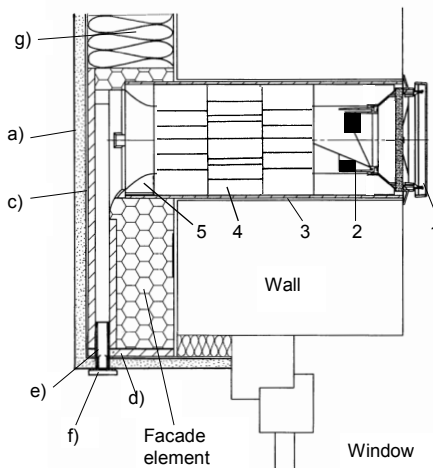

Installation with ALD-S correspondingly

ALD in connection with the facade element LUNOthem FS

Sufficient protection against driving rain must be taken into account. This can be achieved by making sure that the front edge of the window sill completely covers the insect protection screen.

Insect protection screen
The screen can still be removed for maintenance purposes, if a sufficient distance between front edge of window sill and facade surface is set.

Insulation (according to approved ETICS)

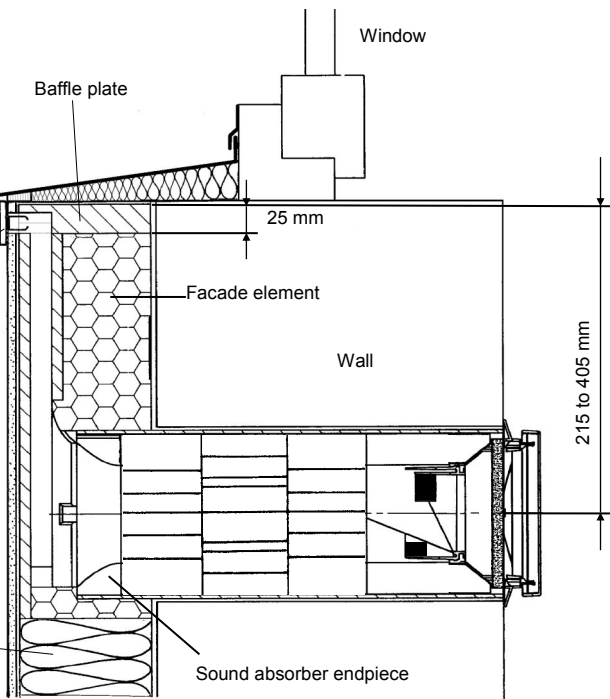

Note: The same applies analogously to the installation of the ALD-S in connection with LUNOthem and LUNOthem FS!

ALD

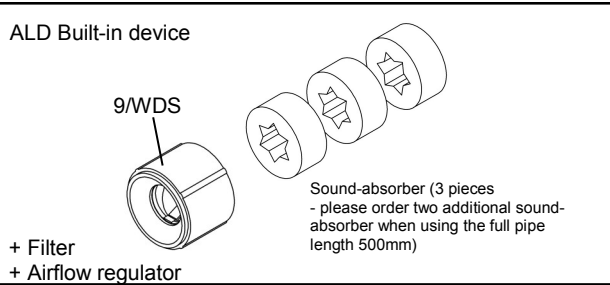

For both version is for completion required

- Wall-tube
- Inner screen
- Outer cover

ALD-S

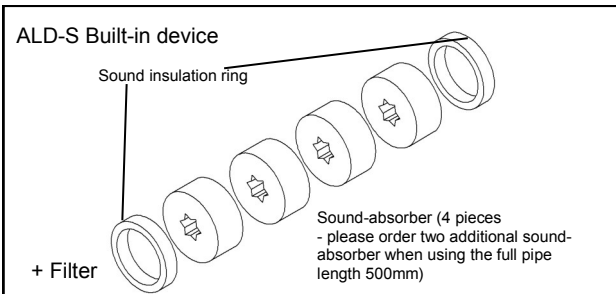

Assembly: ALD

Prepare the wall opening for the wall-tube (e.g. via core drilling, core bit $\varnothing 162$ mm). If necessary, shorten the wall-tube to the installation length required. In doing so, ensure the necessary excess length of the tube on both sides to bridge the plaster thickness. If necessary, reduce the sound-absorber in such a way that the outlined distances to the pipe edge remain the same. If necessary, shorten the outer star-shaped sound-absorber e.g. using a cutter knife. Insert the wall-tube and seal it all around (assembly adhesive Order No. 038 733).

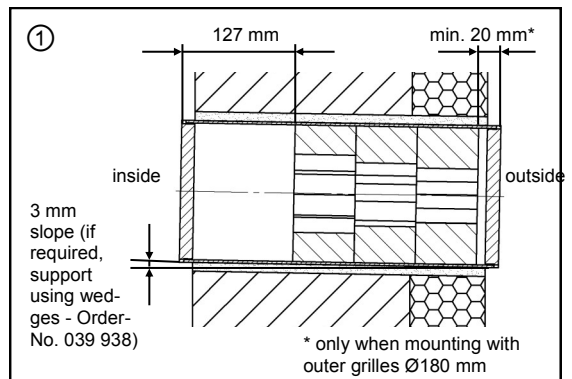

Apply the internal and external plaster. In the case of an external closure to be plastered, first replace the plaster protection cap outside with the external closure.

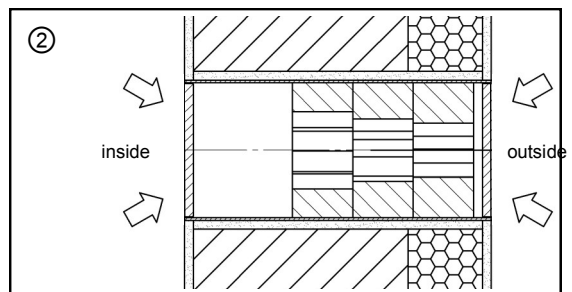

Arrange the sound-absorber twistedly towards one another, as pictured.

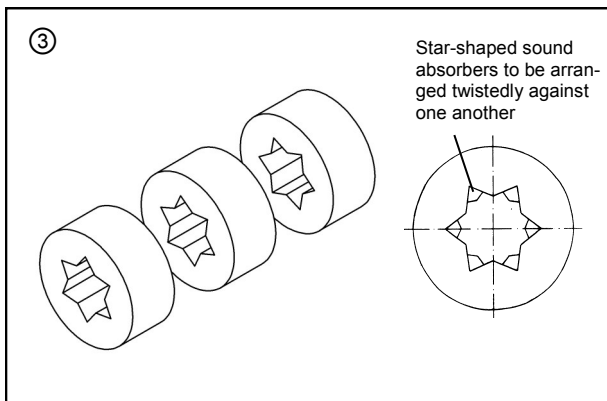

Remove the plaster protection cap. Insert the external closure. Insert the wind pressure relief 9/WDS. In doing so, follow the marking "INNEN OBEN" (inside up) on the wind pressure relief. Assemble the covering frame of the inner screen. In doing so, note that the lettering "LUNOS" is readable at the bottom right. Insert the filter. Snap the design screen of the inner screen in place in open position.

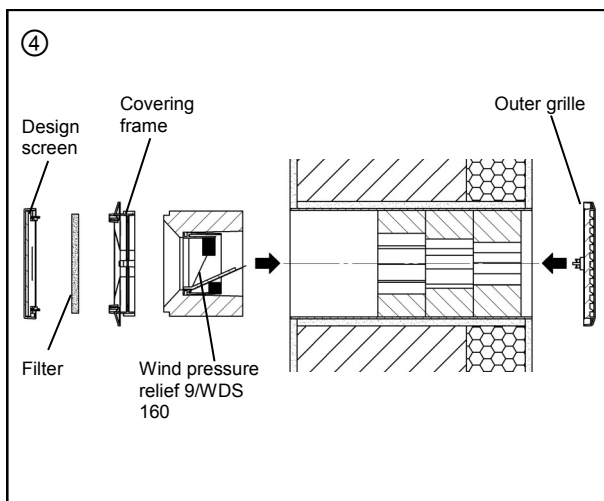

Insert the airflow regulator beneath the filter depending on the design of your ventilation system:
Airflow volumes at 8 Pa static pressure difference:

- 25 m³/h **without** airflow regulator
- 20 m³/h **with** airflow regulator and **extended cross section**
- 15 m³/h **with** airflow regulator **complete**

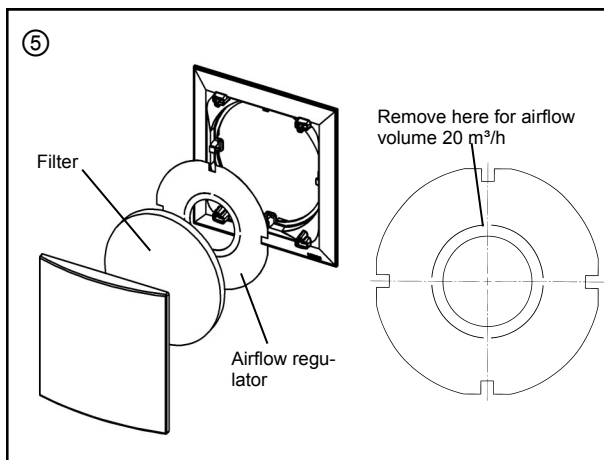

Prepare the wall opening for the wall-tube (e.g. via core drilling, core bit $\varnothing 162$ mm). If necessary, shorten the wall-tube to the installation length required. In doing so, ensure the necessary excess length of the tube on both sides to bridge the plaster thickness. If necessary, reduce the sound-absorber in such a way that the outlined distances to the pipe edge remain the same. If necessary, shorten the outer star-shaped sound-absorber e.g. using a cutter knife. Insert the wall-tube and seal it all around (assembly adhesive Order No. 038 733).

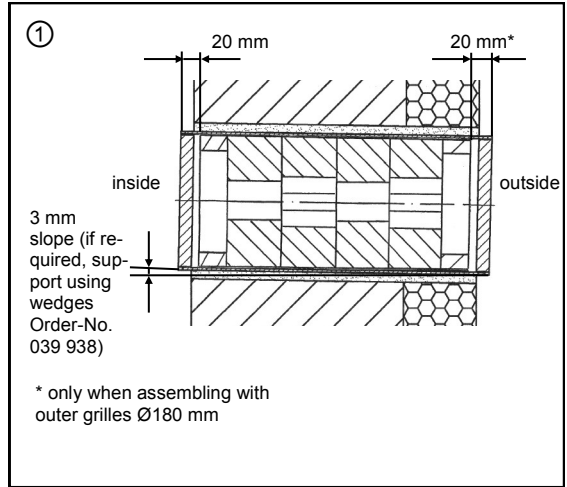

Apply the internal and external plaster. In the case of an external closure to be plastered, first replace the plaster protection cap outside with the external closure.

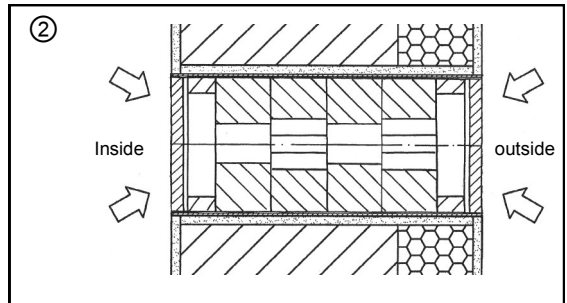

Arrange the sound-absorber twistedly towards one another, as pictured.

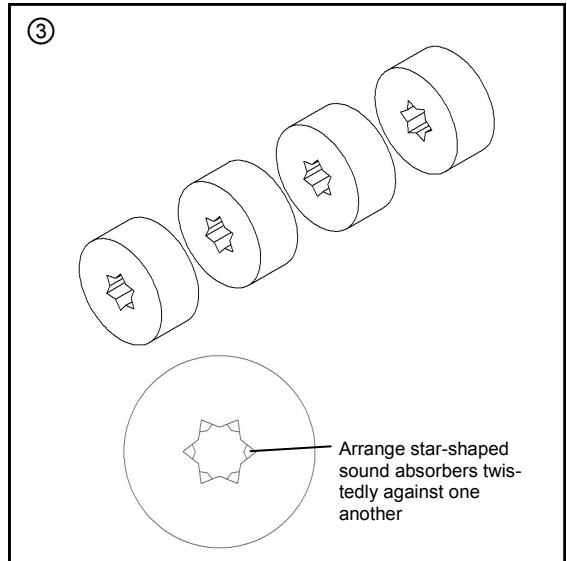

Airflow volume at 8 Pa static pressure difference:

- 15 m³/h

Airflow volume at 4 Pa static pressure difference:

- 10 m³/h

Remove the plaster protection caps. Insert the external closure. Mount the covering frame of the inner screen. In doing so, note that the lettering "LUNOS" is readable at the bottom right. Insert the filter. Snap the design screen of the inner screen into place in open position.

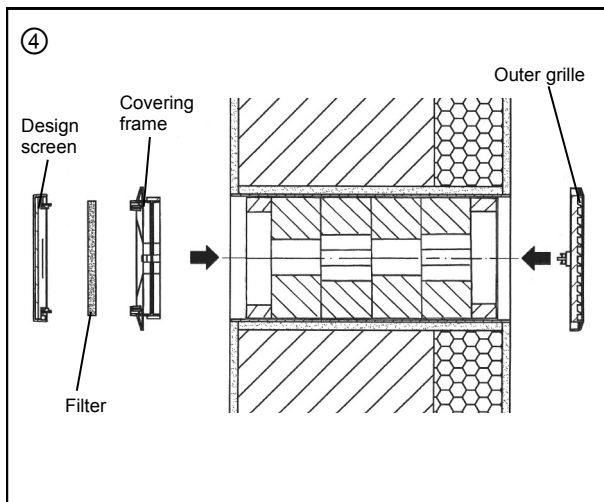

Assembly in connection with LUNOthem and LUNOthem FS

Note: For the assembly of the wall-tube 9/R 160 and the facade element LUNOthem or LUNOthem FS please refer to the corresponding installation manuals.

The sound absorber endpiece is included in the delivery of LUNOthem or LUNOthem FS.

Insert the sound absorber endpiece as pictured und push it to the front edge of the pipe. With the facade element assembled, the pipe has a stop up to which the sound absorber endpiece can be pushed. If necessary, reduce the sound-absorber of the ALD in such a way that the outlined distance of 127 mm to the pipe edge remains the same. This distance is covered by the styrofoam coating of the wind pressure relief. (This distance does not apply to the version ALD-S).

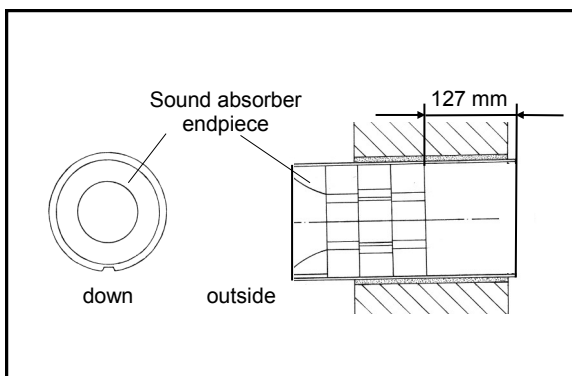

Continue the assembly as described in the chapters on assembly of the ALD and ALD-S.

Check the filter every 3 months for contamination. Clean or replace, if required. After inserting the filter, snap the design screen into place in "open position". The ventilation openings must not be covered or obstructed.

Note: Alternative inner screens are supplied with the corresponding instructions on filter replacement!

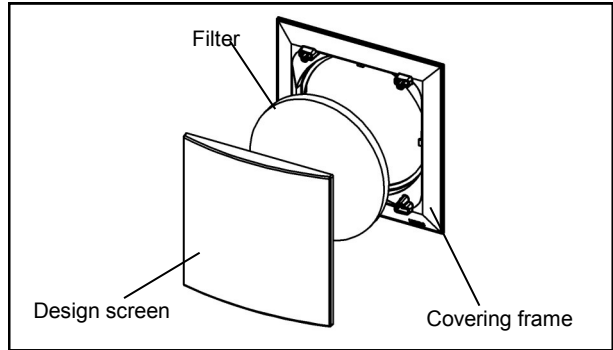

Additional parts and replacement parts

Sound-absorber star-shaped	Type 9/SD-S	Order No.: 039 919
Sound-absorber small star	Type 9/SD-SK	Order No.: 041 134
Airflow regulator	Type 9/VSB	Order No.: 039 920
Replacement filters, five-pack	Type 9/FIB2	Order No.: 037 192
Long-life filters		
Filter class G2, three-pack	Type 9/FIB2R	Order No.: 037 205
Long-life filters		
Filter class G 3, three-pack	Type 9/FIB3R	Order No.: 037 214
Outer grille white	Type 1/WE 180	Order No.: 039 852
Outer grill sanded	Type 1/BE 180	Order No.: 039 917
Outer grill anthracithe	Type 1/AZ 180	Order No.: 041 143
Set of wedges		Order No.: 039 928
Wind pressure relief	Type 9/WDS	Order No.: 037 230

**LUNOS Germany**

LUNOS Lüftungstechnik GmbH
für Raumlufsysteme
Wilhelmstr. 31
13593 Berlin · Germany

Phone +49 30 362 001-0
Fax +49 30 362 001-89
info@lunos.de
www.lunos.de